

SPEEDWAY

SPM-553SFTB Case Sealer

Side Belt Drive

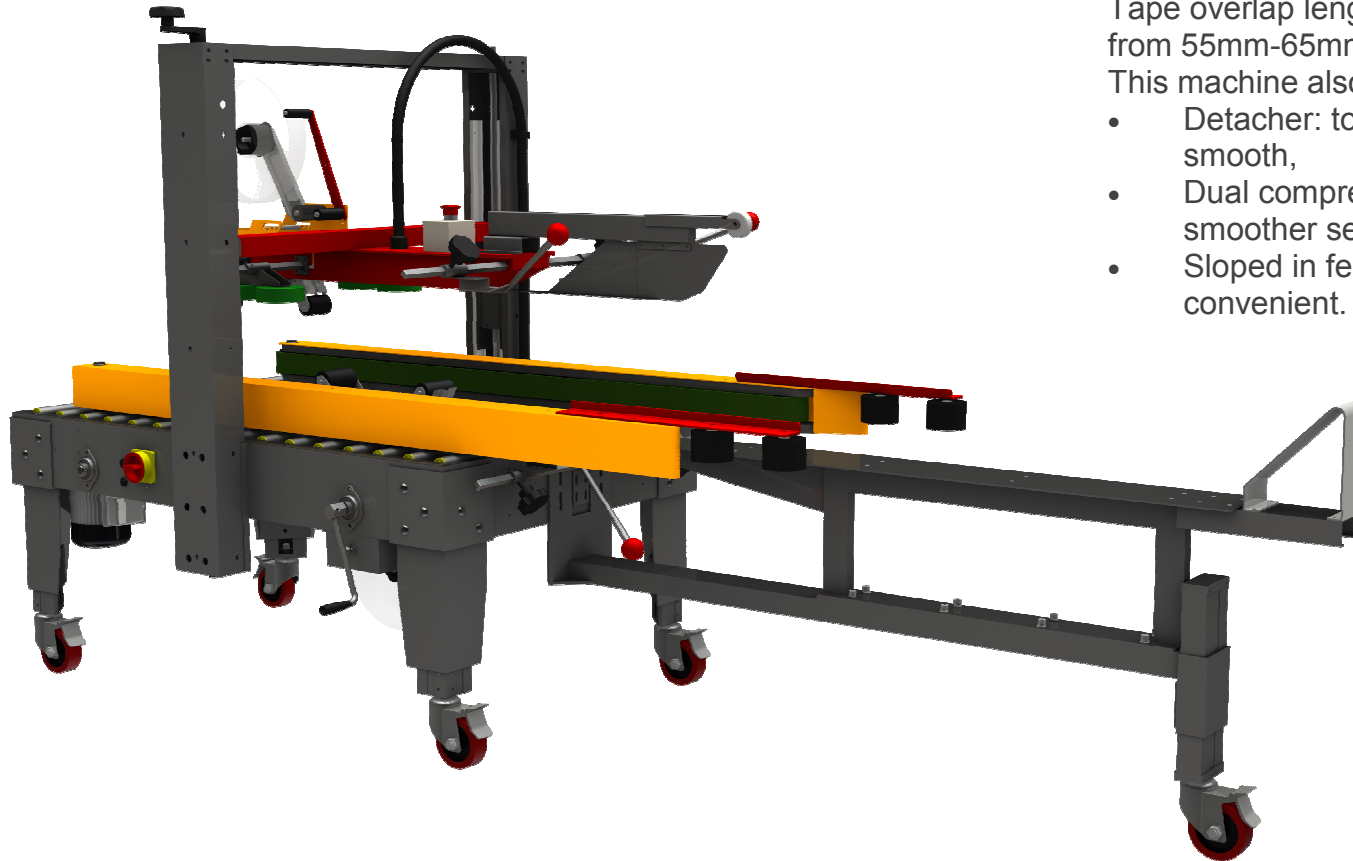

Features:

The **SPM-553SFTB** uses a new taping head incorporating a V shaped plate (patented) designed to keep the tape straight and in position for consistent sealing of every carton. Driven by two side drive belts, each belt has a separate drive mechanism using a special bearing bracket. This provides higher precision, lower noise and lengthens belt life. Tape overlap length can be adjusted from 55mm-65mm.

This machine also features:

- Detacher: to make taping more stabilized and smooth,
- Dual compression rollers: for tighter & smoother sealing.
- Sloped in feed to make flap-folding easier and convenient.

Machine comes standard with
out feed extension roller table
(Not Shown)
L 500 mm x W 530 mm

Speedway Packaging Machinery Inc.
www.spmi.ca

Manufactured in Taiwan

SPM-553SFTB Case Sealer

Specifications

Voltage	110 V 1 PH 60 HZ
Power	10 amps
Sealing Speed	20M/min (66') / min.
Tape Width	2" or 3"
Shipping Weight	225 kg / 500 lbs
Carton Weight	30 kg max
Carton Size	Min: 250mmL x 250mmW x 150mmH 10"L x 10"W x 6"H Max: 500L x 500W x 500H 20"L x 20"W x 20"H

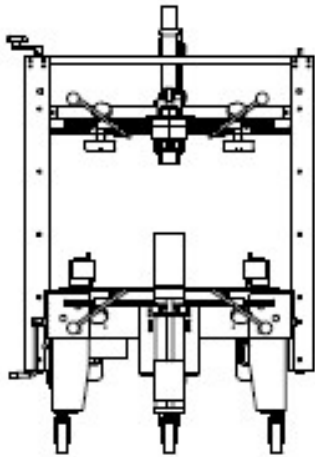

Dimensions

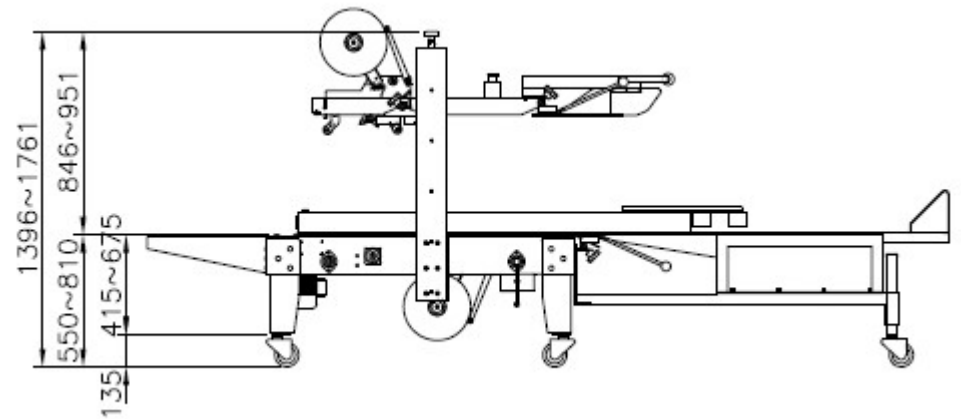
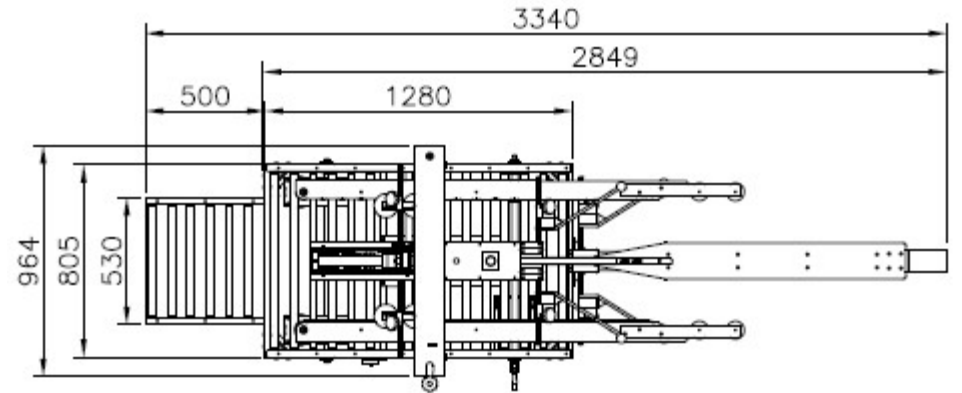

Specifications are subject to change without notice-

NOTE: Not suitable to use these machines if the carton's height exceeds the length.

Manufactured in Taiwan

Distributed by:

SPEEDWAY PACKAGING MACHINERY INC.

P.O. Box 520

10 Gormley Industrial Ave., Unit 1

Gormley, Ontario L0H 1G0

905-888-5344